

# ENC Series

## Wheel type INCREMENTAL Rotary encoder

### ■ Features

- Suitable for measuring the length or speed of target by wheel type
- The output waveform is proportional to the unit of international measurement type
- Power supply : 5VDC, 12–24VDC ±5%

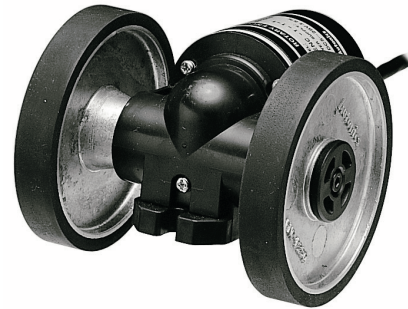

### ■ Application

- Packing machine, Sheet manufacturing , Textile machinery and General industrial plants.

**⚠ Please read "Caution for your safety" in operation manual before using.**



### ■ Ordering information

ENC	-	1	-	1	-	1	-	24	-	2C
Series		Output phase		Min. measuring unit		Output		Power supply		Cable
Wheel type		1 : A, B phase		1 : 1mm 2 : 1cm 3 : 1m 4 : 0.01yd 5 : 0.1yd 6 : 1yd		1 : Totem pole output 2 : NPN open collector output 3 : Voltage output		5 : 5VDC ±5% 24 : 12–24VDC ±5%		No mark:Normal type (*) 2C:Cable outgoing connector type

\*Cable length:200mm

### ■ Specifications

Item	Wheel type Incremental Rotary encoder		
Resolution (P/R)	See resolution (Page L-24)		
Electrical specification	Output phase	A, B phase	
	Phase difference of output	Output between A and B phase : $\frac{T}{4} \pm \frac{T}{8}$ (T=1 cycle of A phase)	
	Control output	Totem pole output	• Low $\Rightarrow$ Load current : Max. 30mA, Residual voltage : Max. 0.4VDC • High $\Rightarrow$ Load current : Max. 10mA, Output voltage : Min. (Power supply-1.5) VDC
		NPN open collector output	Load current : Max. 30mA, Residual voltage : Max. 0.4VDC
		Voltage output	Load current : Max. 10mA, Residual voltage : Max. 0.4VDC
	Response time (Rise/Fall)	Totem pole output	Max. 1 $\mu$ s
		NPN open collector output	Max. 1 $\mu$ s
		Voltage output	Max. 1 $\mu$ s
	Max. Response frequency	180kHz	
	Power supply	5VDC ±5% (Ripple P-P:Max. 5%), 12–24VDC ±5% (Ripple P-P:Max. 5%)	
	Current consumption	Max. 60mA (disconnection of the load)	
	Insulation resistance	Min. 100M $\Omega$ (at 500VDC)	
	Dielectric strength	750VAC 50/60Hz for 1 minute (Between all terminals and case)	
Connection	Cable outgoing type, 200mm cable outgoing connector type		
Mechanical specification	Starting torque	Dependant on coefficient of friction	
	Max. allowable revolution	(★Note1) 5000rpm	
Vibration	1.5mm amplitude at frequency of 10 ~ 55Hz in each of X, Y, Z directions for 2 hours		
Shock	Max. 75G		
Ambient temperature	-10 ~ 70 $^{\circ}$ C (at non-freezing status), Storage: -25 ~ 85 $^{\circ}$ C		
Ambient humidity	35~85%RH, Storage: 35~90%RH		
Cable	5P, $\phi$ 5mm, Length:2m, Shield cable		
Protection	IP50 (IEC specification)		
Weight	Approx. 494g		
Approval	CE		

※ (★Note1) Max. allowable revolution  $\geq$  Max. response revolution 【Max. response revolution (rpm) =  $\frac{\text{Max. response frequency}}{\text{Resolution}} \times 60 \text{ sec}$ 】

Please select the resolution to make lower max. revolution than max. allowable revolution.

# Wheel Measuring Type

## Control output diagram

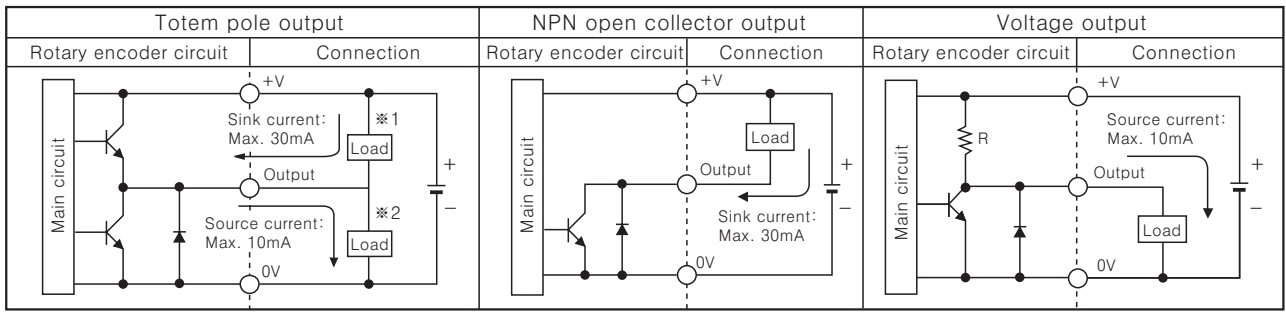

- The output circuit of A, B phase are the same.
- Totem pole output can be used for NPN open collector type(\*1) or voltage output type(\*2).

## Output waveform

- Totem pole output / NPN open collector output / Voltage output

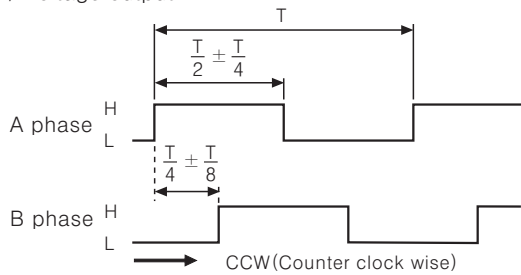

※CCW: Same rotating direction as connection F.G

## Resolution

No	Min. measuring unit	Moving distance per 1pulse	Gear duty	Wheel circumference	SLIT(P/R)
1	1mm	1mm/P	2 : 1	250mm	500Pulse
2	1cm	1cm/P	4 : 1	250mm	100Pulse
3	1m	1m/P	4 : 1	250mm	1Pulse
4	0.01yd	0.01yd/P	4 : 1	228.6mm (0.25/yd)	100Pulse
5	0.1yd	0.1yd/P	4 : 1	228.6mm (0.25/yd)	10Pulse
6	1yd	1yd/P	4 : 1	228.6mm (0.25/yd)	1Pulse

## Connections

### Connector type

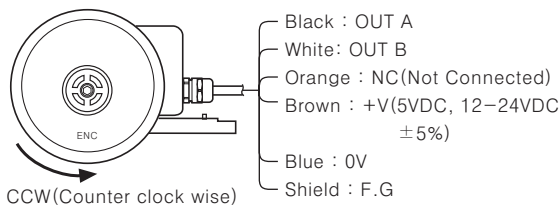

- ※Unused wires must be insulated.
- ※The shield wire and metal case of encoder must be grounded(F.G)

### Cable outgoing connector type



Pin No.	Cable color	Totem pole output NPN open collector output Voltage output
①	Black	OUT A
②	Red	N.C
③	Brown	+V
④	Blue	GND
⑤	White	OUT B
⑥	Gray	N.C
⑦	Orange	OUT Z
⑧	Yellow	N.C
⑨	Shield	F.G
⑩	Purple	N.C

- ※N.C(Not Connected)
- ※F.G(Field Ground)

## Dimensions

Unit:mm

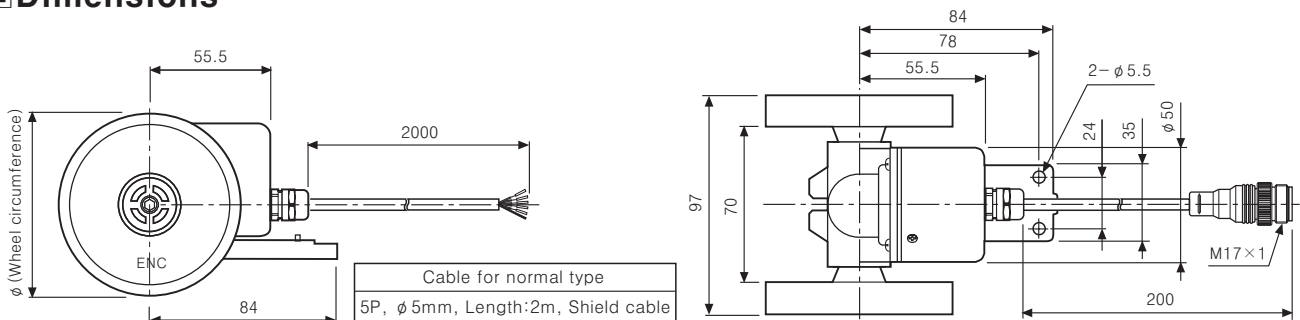

- ※The wheel of revolution is changed according to circumference(φ), please see resolution chart.

- Connector cable(Accessory)

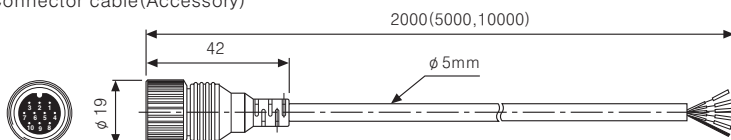

Connector cable model  
EC5-2(Standard),  
EC5-5, EC5-10

Connector cable model  
EC 5 - 2  
└ Cable length(m)  
└ The number of cables  
└ Connector cable of Encoder

※A cable length is optional.

(A) Counter

(B) Timer

(C) Temp. controller

(D) Power controller

(E) Panel meter

(F) Tacho/ Speed/ Pulse meter

(G) Display unit

(H) Sensor controller

(I) Proximity sensor

(J) Photo electric sensor

(K) Pressure sensor

(L) Rotary encoder

(M) 5-Phase stepping motor & Driver & Controller