

West P6170 ¹/₁₆ Din Valve Motor Controller



The new Plus Series VMD Controllers have been specifically designed for open loop valve motor drive applications and feature the improved Plus Series interface and greater field flexibility.

- Jumperless Configuration
- Auto or Manual Tuning
- Auto Detected Hardware
- Motorised Valve Control
- Process & Loop Alarms
- Valve Position Indication
- Modbus Communications
- Remote/Dual Setpoint Options



Technical Data

Features

Control Types	Full PID with Pre-tune, Self-tune and manual tuning modes.
Valve Control	Open Loop Valve Motor Drive.
Auto/Manual	Selectable from front panel or via digital input, with bumpless transfer.
Output Configuration	Up to 4 possible, two required for valve control, additional outputs for alarm, 24VDC transmitter power supply or retransmit of process value or setpoint.
Alarm 1 & 2 Types	Process high, process low, SP deviation, band, logical OR / AND. Also 1 loop alarm for process control security. Process alarms have adjustable hysteresis.
Human Interface	4 button operation, dual 4 digit 10mm & 8mm high LED displays, optional choice of colours (Red/Red, Red/Green, Green/Red or Green/Green), plus 5 LED indicators
PC Configuration	Off-line configuration from PC serial port to dedicated configuration socket (communications option not required). Configuration Software for Windows 98 or higher. West Part Number: PS1-CON

Input

Thermocouple	J, K, C, R, S, T, B, L, N & PtRh20%vsPtRh40%.
RTD	3 Wire PT100, 50Ω per lead maximum (balanced)
DC Linear	0 to 20mA, 4 to 20mA, 0 to 50mV, 10 to 50mV, 0 to 5V, 1 to 5V, 0 to 10V, 2 to 10V. Scaleable -1999 to 9999, with adjustable decimal point
Impedance	>10MΩ for Thermocouple and mV ranges, 47KΩ for V ranges and 5Ω for mA ranges
Accuracy	±0.1% of input range ±1 LSD (T/C CJC better than 1°C)
Sampling	4 per second, 14 bit resolution approximately
Sensor Break Detection	<2 seconds (except zero based DC ranges), control O/P's turn off, high alarms activate for T/C and mV ranges, low alarms activate for RTD, mA or V ranges

Outputs & Options

Control & Alarm Relays	Contacts SPDT 2 Amp resistive at 240V AC (120V AC Max for direct VMD), >500,000 operations. (1A 2xSPST 200,000 operations for Dual Relay)
Control SSR Driver Outputs	Drive capability >10V DC in 500Ω minimum
Triac Outputs	0.01 to 1 Amp AC, 20 to 280Vrms, 47 to 63Hz. 140V Max for direct VMD.
DC Linear Outputs	0 to 20mA, 4 to 20mA into 500Ω max, 0 to 10V, 2 to 10V, 0 to 5V into 500Ω min. Accuracy ±0.25% at 250Ω (degrades linearly to 0.5% for increasing burden to specified limits) Retransmit of PV or SP Only.
Transmitter Power Supply	Output 24VDC (nominal) into 910Ω minimum to power external devices
Serial Communications	2 Wire RS485, 1200 to 19200 Baud, Modbus protocol
Digital Input	Selects between 2 setpoints or Auto/Manual control. Volt free or TTL input
Remote Setpoint / Valve Position Auxiliary Input	0 to 20mA, 4 to 20mA, 0 to 5V, 1 to 5V, 0 to 10V or 2 to 10V. Scaleable -1999 to 9999. For Valve Position Indication or Remote Setpoint Input.

Operating & Environmental

Temperature & RH	0 to 55°C (-20 to 80°C storage), 20% to 95% RH non-condensing
Power Supply	100 to 240V 50/60Hz 7.5VA (optional 20 to 48V AC 7.5VA/22 to 65V DC 5 watts)
Front Panel Protection	IEC IP66 (Behind panel protection is IP20)
Standards	CE, UL & ULC recognised

In accordance with our policy of continuous improvement, we reserve the right to change specifications from those shown in this document
P6170 Spec sheet - 01/06

Dimensions

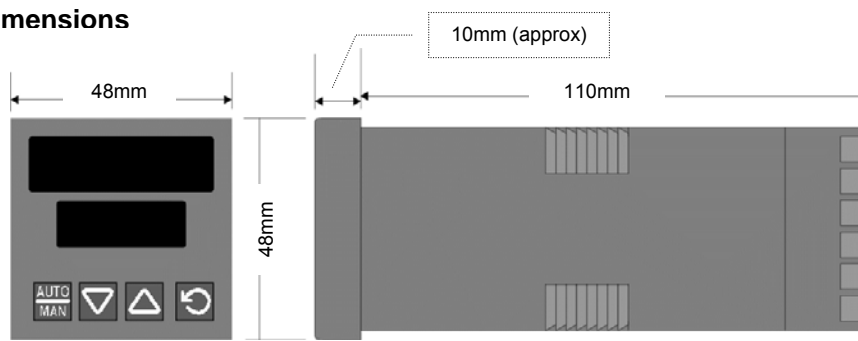

Cut out

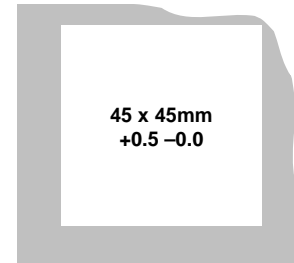

Connection Details

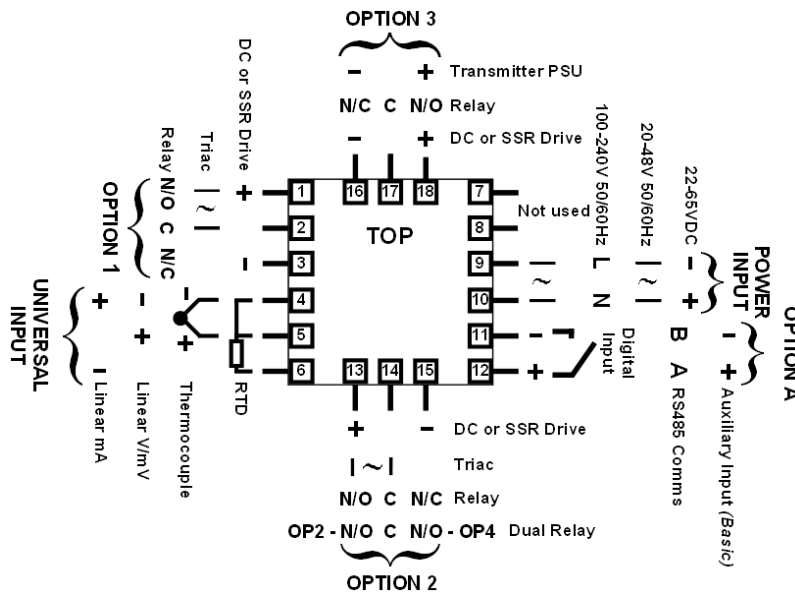

Field Reconfiguration

Input

Jumper-free configuration for any type
(no extra parts required)

Option Slot 1	Part Number
Relay Output.....	PO1-C10
Linear mA/V DC Output.....	PO1-C21
SSR Driver Output.....	PO1-C50
Triac Output.....	PO1-C80
Option Slot 2	Part Number
Relay Output.....	PO2-C10
Linear mA/V DC Output.....	PO2-C21
SSR Driver Output.....	PO2-C50
Triac Output.....	PO2-C80
Dual Relay Output.....	PO2-W09
Option Slot 3	Part Number
Relay Output.....	PO2-C10
Linear mA/V DC Output.....	PO2-C21
SSR Driver Output.....	PO2-C50
24VDC Transmitter PSU.....	PO2-W08
Option Slot A	Part Number
Digital Input.....	PA1-W03
Auxiliary Input (Basic).....	PA1-W04
RS485 Comms.....	PA1-W06

Order Code



Input Type

3 Wire RTD or DC mV	1
Thermocouple	2
DC mA	3
DC Voltage	4

Option Slot 1

Not fitted	0
Relay	1
DC for SSR	2
DC 0-10V	3
DC 0-20mA	4
DC 0-5V	5
DC 2-10V	6
DC 4-20mA	7
Triac	8

Option Slot 2

Not fitted	0
Relay	1
DC Driver for SSR	2
DC 0-10V	3
DC 0-20mA	4
DC 0-5V	5
DC 2-10V	6
DC 4-20mA	7
Triac	8
Dual Relay	9

Display Color

0	Red Upper & Lower
1	Green Upper & Lower
2	Red Upper, Green Lower
3	Green Upper, Red Lower

Power Supply

0	100-240V AC
2	24-48V AC or DC

Option Slot A

0	Not fitted
1	RS485 Communications
3	Digital Input
4	Auxiliary Input (Basic)

Option Slot 3

0	Not fitted
1	Relay
2	DC Driver for SSR
3	DC 0-10V
4	DC 0-20mA
5	DC 0-5V
6	DC 2-10V
7	DC 4-20mA
8	Transmitter Power Supply