

ABRAF

1/16 - 1/8 - 1/4 DIN VMD CONTROLLERS

CONCISE PRODUCT MANUAL (59377-1)

CAUTION: Installation should be only performed by technically competent personnel. Local Regulations regarding electrical installation & safety must be observed.

1. INSTALLATION

The models covered by this manual have three different DIN case sizes (refer to section 10). Some installation details vary between models. These differences have been clearly shown.

Note: The functions described in sections 2 thru 9 are common to all models.

Installing Option Modules

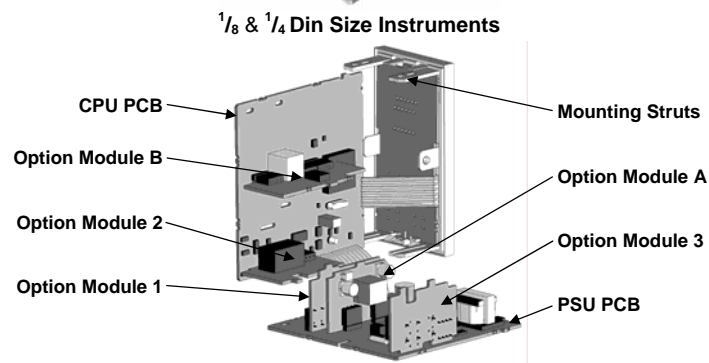
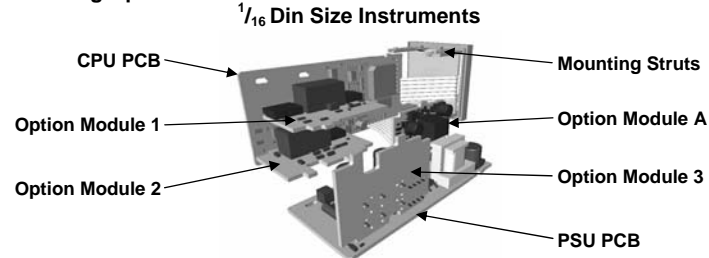

To access modules 1, A or B, first detach the PSU and CPU boards from the front by lifting first the upper, and then lower mounting struts. Gently separate the boards.

- Plug the required option modules into the correct connectors, as shown below.
- Locate the module tongues in the corresponding slot on the opposite board.
- Hold the main boards together while relocating back on the mounting struts.
- Replace the instrument by aligning the CPU and PSU boards with their guides in the housing, then slowly push the instrument back into position.

Note: Option modules are automatically detected at power up.

Option Module Connectors

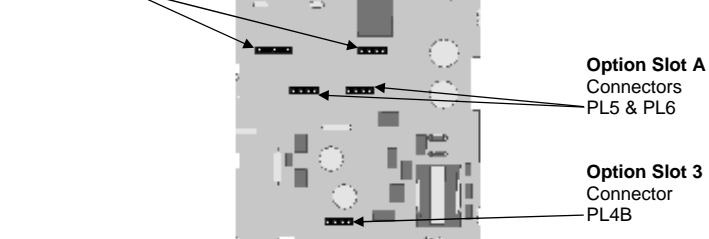
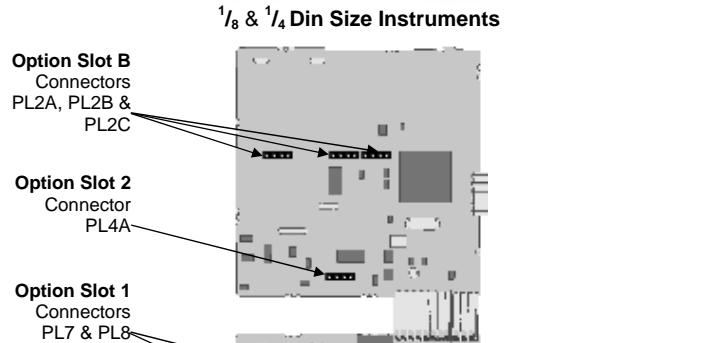
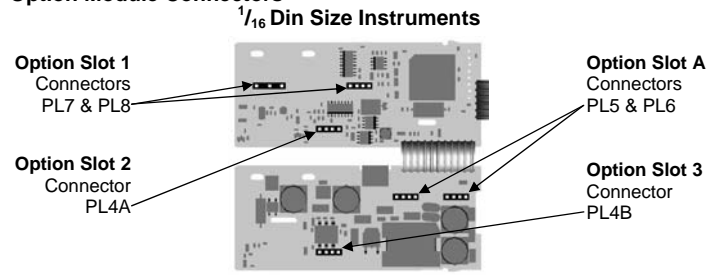

Panel-Mounting

The mounting panel must be rigid, and may be up to 6.0mm (0.25inch) thick. Cut-out sizes are:

Cut-Out Dim A
1/16 & 1/8 Din = 45mm
1/4 Din = 92mm

Cut-Out Dim B
1/16 Din = 45mm
1/8 & 1/4 Din = 92mm

For *n* multiple instruments mounted side-by-side, cut-out A is 48*n*-4mm (1/16 & 1/8 Din) or 96*n*-4mm (1/4 Din)

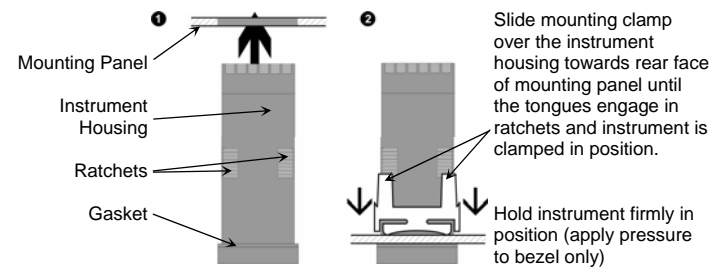

CAUTION: Do not remove the panel gasket; it is a seal against dust and moisture.

Rear Terminal Wiring

USE COPPER CONDUCTORS (EXCEPT FOR T/C INPUT)
Single Strand wire gauge: Max 1.2mm (18SWG)

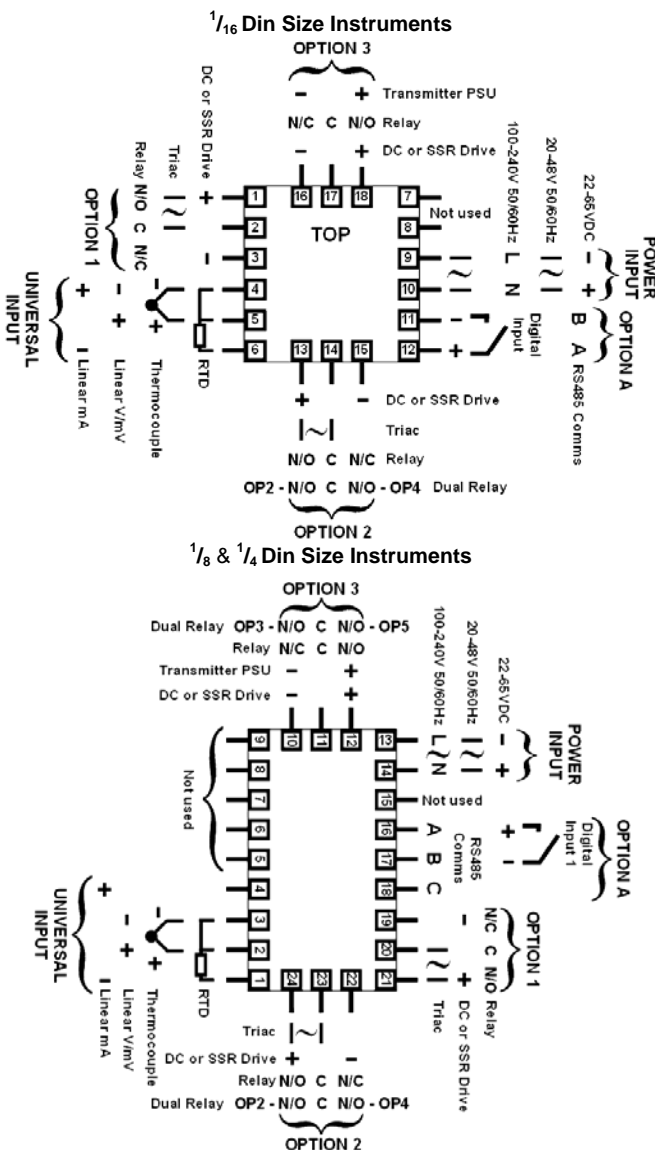

Note: These diagrams show all possible option combinations. The actual connections required depends on the exact model and options fitted.

CAUTION: Check information label on housing for correct operating voltage before connecting supply to Power Input
Fuse: 100 – 240V ac – 1amp anti-surge
24/48V ac/dc – 315mA anti-surge

Note: At first power-up the message `Go to Conf` is displayed, as described in section 7 of this manual. Access to other menus is denied until configuration mode is completed

2. SELECT MODE

Select mode is used to access the configuration and operation menu functions. It can be accessed at any time by holding down `⏏` and pressing `⏏`. In select mode, press `⏏` or `⏏` to choose the required mode, press `⏏` to enter. An unlock code is required to prevent unauthorised entry to Configuration, & Setup modes. Press `⏏` or `⏏` to enter the unlock code, and then press `⏏` to proceed.

Mode	Upper Display	Lower Display	Description	Default Unlock Codes
Operator	OPtr	SLCt	Normal operation	None
Set Up	SEtP	SLCt	Tailor settings to the application	10
Configuration	CoNF	SLCt	Configure the instrument for use	20
Product Info	inFo	SLCt	Check manufacturing information	None
Auto-Tuning	Atun	SLCt	Invoke Pre-Tune or Self-Tune	0

Note: The instrument will always return automatically to Operator mode if there is no key activity for 2 minutes.

3. CONFIGURATION MODE

First select Configuration mode from Select mode (refer to section 2). Press `⏏` to scroll through the parameters, then press `⏏` or `⏏` to set the required value. Press `⏏` to accept the change, otherwise parameter will revert to previous value. To exit from Configuration mode, hold down `⏏` and press `⏏`, to return to Select mode.

Note: Parameters displayed depends on how instrument has been configured. Refer to user guide (available from your supplier) for further details. Parameters marked * are repeated in Setup Mode.

Parameter	Lower Display	Upper Display	Adjustment range & Description	Default Value	
Input Range/Type	inPt		See following table for possible codes	JC	
Code	Input Type & Range	Code	Input Type & Range	Code	Input Type & Range
bC	B: 100 - 1824 °C	LC	L: 0.0 - 537.7 °C	P24F	PtRh20% vs 40%: 32 - 3362 °F
bF	B: 211 - 3315 °F	LF	L: 32.0 - 999.9 °F	PtC	Pt100: -199 - 800 °C
cC	C: 0 - 2320 °C	nC	N: 0 - 1399 °C	PtF	Pt100: -328 - 1472 °F
cF	C: 32 - 4208 °F	nF	N: 32 - 2551 °F	PtL	Pt100: -128.8 - 537.7 °C
JC	J: -200 - 1200 °C	rC	R: 0 - 1759 °C	PtF	Pt100: -199.9 - 999.9 °F
JF	J: -328 - 2192 °F	rF	R: 32 - 3198 °F	PtL	Pt100: -199.9 - 999.9 °F
J.C	J: -128.8 - 537.7 °C	S.C	S: 0 - 1762 °C	0.20	0 - 20 mA DC
J.F	J: -199.9 - 999.9 °F	S.F	S: 32 - 3204 °F	4.20	4 - 20 mA DC
H.C	K: -240 - 1373 °C	t.C	T: -240 - 400 °C	0.50	0 - 50 mV DC
H.F	K: -400 - 2503 °F	t.F	T: -400 - 752 °F	10.50	10 - 50 mV DC
H.C	K: -128.8 - 537.7 °C	t.C	T: -128.8 - 400.0 °C	0.5	0 - 5 V DC
H.F	K: -199.9 - 999.9 °F	t.F	T: -199.9 - 752.0 °F	1.5	1 - 5 V DC
LC	L: 0 - 762 °C	P24C	PtRh20% vs. 40%: 0 - 1850 °C	0.10	0 - 10 V DC
LF	L: 32 - 1403 °F	P24F	PtRh20% vs. 40%: 0 - 1850 °C	2.10	2 - 10 V DC

Note: Decimal point shown in table indicates temperature resolution of 0.1°

Parameter	Lower Display	Upper Display	Adjustment range & Description	Default Value
Scale Range Upper Limit	rUL		Scale Range Lower Limit +100 to Range Maximum	Range max (Lin=1000)
Scale Range Lower Limit	rLL		Range Minimum to Scale Range Upper Limit -100	Range min (Linear=0)
Decimal point position	dPoS		0=xxxx, 1=xxx.x, 2=xx.xx, 3=x.xxx (non-temperature ranges only)	1
Primary Output Control Action	CtrL	rEu	Reverse Acting	rEu
Motor Travel Time	tr		5 secs to 5 mins	1.00
Alarm 1Type	ALR1	P_H1	Process High Alarm	P_H1
		P_Lo	Process Low Alarm	
		dE	Deviation Alarm	
		bAnd	Band Alarm	
		nonE	No alarm	
High Alarm 1 value*	PhR1		Range Minimum to Range Maximum in display units	Range Max
Low Alarm 1 value*	PLR1		Range Minimum to Range Maximum in display units	Range Min
Band Alarm 1 value*	bAL1		1 LSD to span from setpoint in display units	S
Dev. Alarm 1 value*	dAL1		+/- Span from setpoint in display units	S
Alarm 1 Hysteresis*	AHY1		1 LSD to full span in display units	1
High Alarm 2 value*	PhR2		Options as for alarm 1	Range Max
Low Alarm 2 value*	PLR2		Options as for alarm 1	Range Min
Band Alarm 2 value*	bAL2		Options as for alarm 1	S

Parameter	Lower Display	Upper Display	Adjustment range & Description	Default Value
Dev. Alarm 2 Value*	dAL2		Options as for alarm 1	S
Alarm 2 Hysteresis*	AHY2		Options as for alarm 1	1
Loop Alarm	LAEn		d.SA (disabled) or EnAb (enabled)	d.SA
Alarm Inhibit	Inh1		nonE No alarms Inhibited ALA1 Alarm 1 inhibited ALA2 Alarm 2 inhibited both Alarm 1 and alarm 2 inhibited	nonE
Output 1 Usage	USE1		OPn Valve Open CLS Valve Close A1_d Alarm 1, Direct A1_r Alarm 1, Reverse A2_d Alarm 2, Direct A2_r Alarm 2, Reverse LP_d Loop Alarm, Direct LP_r Loop Alarm, Reverse Or_d Logical Alarm 1 OR 2, Direct Or_r Logical Alarm 1 OR 2, Reverse Ad_d Logical Alarm 1 AND 2, Direct Ad_r Logical Alarm 1 AND 2, Reverse rEtS Retransmit SP Output rEtP Retransmit PV Output	OPn
Linear Output 1 Range	tYP1		0.5 0 to 5 V DC output 0.10 0 to 10 V DC output 2.10 2 to 10 V DC output 0.20 0 to 20 mA DC output 4.20 4 to 20 mA DC output	0.10
Retransmit Output 1 Scale maximum	ro1H		-1999 to 9999 (display value at which output will be maximum)	Range max
Retransmit Output 1 Scale minimum	ro1L		-1999 to 9999 (display value at which output will be minimum)	Range min
Output 2 Usage	USE2		As for output 1	CLS
Linear Output 2 Range	tYP2		As for output 1	0.10
Retransmit Output 2 Scale maximum	ro2H		-1999 to 9999 (display value at which output will be maximum)	Range max
Retransmit Output 2 Scale minimum	ro2L		-1999 to 9999 (display value at which output will be minimum)	Range min
Output 3 Usage	USE3		As for output 1	A1_d
Linear Output 3 Range	tYP3		As for output 1	0.10
Retransmit Output 3 Scale maximum	ro3H		-1999 to 9999 (display value at which output will be maximum)	Range max
Retransmit Output 3 Scale minimum	ro3L		-1999 to 9999 (display value at which output will be minimum)	Range min
Output 4 Usage	USE4		OPn Valve Open CLS Valve Close A1_d Alarm 1, Direct A1_r Alarm 1, Reverse A2_d Alarm 2, Direct A2_r Alarm 2, Reverse LP_d Loop Alarm, Direct LP_r Loop Alarm, Reverse Or_d Logical Alarm 1 OR 2, Direct Or_r Logical Alarm 1 OR 2, Reverse Ad_d Logical Alarm 1 AND 2, Direct Ad_r Logical Alarm 1 AND 2, Reverse	A1_d
Output 5 Usage	USE5		As for output 4	A1_d
Display Strategy	d.SP		1, 2, 3, 4, 5, 6 or 7 (refer to section 8)	1
Serial Communications Protocol	Prot		ASC1 ASCII P7bn Modbus with no parity P7bE Modbus with Even Parity P7bo Modbus with Odd Parity	P7bn
Serial Communications Bit Rate	bAud		1.2 1.2 kbps 2.4 2.4 kbps 4.8 4.8 kbps 9.6 9.6 kbps 19.2 19.2 kbps	4.8
Comms Address	Addr		1 to 255 (Modbus), 1 to 99 (ASCII)	1
Comms Write	CoEn		r.WJ Read/Write r.D Read only	r.WJ
Auxiliary Option A Usage	A.PR		r.SP Remote Setpoint P.in Valve Position Indication	P.in

Parameter	Lower Display	Upper Display	Adjustment range & Description	Default Value
Auxiliary Option B Usage	R Pb	rSP	Remote Setpoint Valve Position Indication	P
Digital Input 1 Usage	d i1	d i5 d iAS	Setpoint 1 / Setpoint 2 select* Automatic / Manual select	d i5
Digital Input 2 Usage	d i2	d i5 d iAS d iR5	Setpoint 1 / Setpoint 2 select* Automatic / Manual select Remote / Local setpoint select	d iR5
Remote Setpoint Input Range	r inP	0 _20	0 to 20 mA DC input	0 _10
		4 _20	4 to 20 mA DC input	
		0 _10	0 to 10 V DC input	
		2 _10	2 to 10 V DC input	
		0 _5	0 to 5 V DC input	
		1 _5	1 to 5 V DC input	
		100	0 to 100mV DC input Potentiometer (2KΩ minimum) (Slot B) only	
RSP Upper Limit	rSPu		-1999 to 9999	Range max
RSP Lower Limit	rSPl		-1999 to 9999	Range min
RSP Offset	rSPo		Constrained within Scale Range Upper & Scale Range Lower limits	0
Configuration Lock Code	CLoc		0 to 9999	20

Note: **d i2** has priority over **d i1** if both are configured for the same usage. If **d i1** or **d i2 = d i5** the remote setpoint input is disabled.

4. SETUP MODE

Note: Configuration must be completed before adjusting Setup parameters. First select Setup mode from Select mode (refer to section 2). The MAN LED will light while in Setup mode. Press **⏏** to scroll through the parameters, then press **▲** or **▼** to set the required value. To exit from Setup mode, hold down **⏏** and press **▲** to return to Select mode. Note: Parameters displayed depends on how instrument has been configured.

Parameter	Lower Display	Upper Display	Adjustment Range & Description	Default Value
Input Filter Time Constant	F iL		OFF or 0.5 to 100.0 secs	2.0
Process Variable Offset	OFFS		±Span of controller	0
Primary Proportional Band	Pb P		0.5% to 999.9% of input span	10.0
Automatic Reset (Integral Time)	RrSt		1 sec to 99 mins 59 secs	5.00
Rate (Derivative Time)	rRtE		00 secs to 99 mins 59 secs	0
Setpoint Upper Limit	SPuL		Current Setpoint to Range max	R/max
Setpoint Lower limit	SPlL		Range min to Current Setpoint	R/min
Minimum Motor On Time	tOn		0.0 secs to (Motor Travel Time / 10) secs	1.0
Set Valve Open Position	PcUL		Valve Maximum Position Clamp	Aux R/max
Set Valve Closed Position	PcLL		Valve Minimum Position Clamp	Aux R/min
Valve Open Limit	P iUL		Valve Maximum Position	100
Valve Close Limit	P iLL		Valve Minimum Position	0
High Alarm 1 value	PhA1		Range Minimum to Range Maximum	R/max
Low Alarm 1 value	PLA1		Maximum	R/min
Deviation Alarm 1 Value	dAL1		±Span from SP in display units	5
Band Alarm 1 value	bAL1		1 LSD to span from setpoint	5
Alarm 1 Hysteresis	AHY1		1 LSD to full span in display units	1
High Alarm 2 value	PhA2		Range Minimum to Range Maximum	R/max
Low Alarm 2 value	PLA2		Maximum	R/min
Deviation Alarm 2 Value	dAL2		±Span from SP in display units	5
Band Alarm 2 value	bAL2		1 LSD to span from setpoint	5
Alarm 2 Hysteresis	AHY2		1 LSD to full span in display units	1
Auto Pre-tune	APt			
Auto/manual Control selection	PaEn			
Setpoint Select shown in Operator Mode	SEEn		d iSA (disabled) or EnRb (enabled)	d iSA
Setpoint ramp adjustment shown in Operator Mode	SPr			
SP Ramp Rate Value	rP		1 to 9999 units/hour or Off (blank)	Off
Setpoint Value	SP		Scale range upper to lower limits. (when dual or remote setpoint options are used, SP is replaced by SP1 & SP2 or LSP - or - before the legend indicates the currently active SP)	Scale Range Minimum
Local Setpoint Value	_LSP			
Setpoint 1 Value	_SP1			
Setpoint 2 Value	_SP2			
Setup Lock Code	SLoc			

5. AUTOMATIC TUNING MODE

First select Automatic tuning mode from Select mode (refer to section 2). Press **⏏** to scroll through the modes, then press **▲** or **▼** to set the required value. To exit from Automatic tuning mode, hold down **⏏** and press **▲** to return to Select mode. Pre-tune is a single-shot routine and is thus self-disengaging when complete. If **APt** in Setup mode = **EnRb**, Pre-tune will attempt to run at every power up*. Refer to the full user guide (available from your supplier) for details on controller tuning.

Parameter	Lower Display	Upper Display	Default Value
Pre-Tune	Ptun	On or OFF . Indication remains OFF if automatic tuning cannot be used at this time*	OFF
Self-Tune	Stun		OFF
Tune Lock	tLoc	0 to 9999	0

Also, Pre-tune will not engage if setpoint is ramping, or the PV is less than 5% of input span from the setpoint.

6. PRODUCT INFORMATION MODE

First select Product information mode from Select mode (refer to section 2). Press **⏏** to view each parameter. To exit from Product Information mode, hold down **⏏** and press **▲** to return to Select mode. Note: These parameters are all read only.

Parameter	Lower Display	Upper Display	Description
Input type	in i	Un i	Universal input No option fitted
Option 1 module type fitted	OPn1	nonE	No option fitted
		rLY	Relay output
		SSr	SSR drive output
		tRi	Triac output
Option 2 module type fitted	OPn2	L in	Linear DC voltage / current output
		dRLY	As Option 1 & Dual relay output
Option 3 module type fitted	OPn3	nonE	No option fitted
		rLY	Relay output
		dRLY	Dual relay output
		SSr	SSR drive output
		L in	Linear DC voltage / current output
Auxiliary Option A module type fitted	OPnA	dc24	Transmitter power supply
		nonE	No option fitted
		r485	RS485 communications
Auxiliary Option B module type fitted	OPnb	d i1	Digital Input*
		rSP1	Remote Setpoint Input (basic)*
Firmware type	FLuJ	nonE	No option fitted
		rSP1	Remote Setpoint Input (full) and Digital Input 2*
Firmware issue	ISS		Value displayed is firmware issue number
Product Revision Level	PRL		Value displayed is Product Revision level
Date of manufacture	d0P7		Manufacturing date code (mmyy)
Serial number 1	Sn1		First four digits of serial number
Serial number 2	Sn2		Middle four digits of serial number
Serial number 3	Sn3		Last four digits of serial number

7. MESSAGES & ERROR INDICATIONS

These messages indicate that an error has occurred or there is a problem with the process variable input signal or its wiring.

Caution: Do not continue with the process until the issue is resolved.

Parameter	Upper Display	Lower Display	Description
Instrument parameters are in default conditions	GoTo	ConF	Configuration & Setup required. This screen is seen at first turn on, or if hardware configuration has been changed. Press ⏏ to enter the Configuration Mode, next press ▲ or ▼ to enter the unlock code number, then press ⏏ to proceed
Input Over Range	CHH	Normal	Process variable input > 5% over-range
Input Under Range	CLL	Normal	Process variable input > 5% under-range
Input Sensor Break	OPEN	Normal	Break detected in process variable input sensor or wiring
RSP Over Range	CHH	**	RSP input over-range
RSP Under Range	CLL	**	RSP input under-range
RSP Break	OPEN	**	Break detected in RSP input signal
Option 1 Error	Err	OPn1	Option 1 module fault
Option 2 Error		OPn2	Option 2 module fault
Option 3 Error		OPn3	Option 3 module fault
Option A Error		OPnA	Option A module fault or RSP in both A & B

Option B Error	OPnb	Option B module fault
----------------	-------------	-----------------------

8. OPERATOR MODE

This mode is entered at power on, or accessed from Select mode (see section 2). Note: All Configuration mode and Setup mode parameters must be set as required before starting normal operations. Press **⏏** to scroll through the parameters, then press **▲** or **▼** to set the required value. Note: All Operator Mode parameters in Display strategy 6 are read only (see **d iSP** in configuration mode), they can only be adjusted via Setup mode.

Upper Display	Lower Display	Display Strategy and When Visible	Description
PV Value	Active SP Value	1, 2 & 7 (initial screen)	PV and target value of selected SP Local Setpoints are adjustable in Strategy 2 & 7
PV Value	Actual SP Value	3 & 6 (initial screen)	PV and actual value of selected SP (e.g. ramping SP value). Read only
PV Value	(Blank)	4 (initial screen)	Process variable only Read only
Active SP Value	(Blank)	5 (initial screen)	Target value of selected setpoint only. Read only
PV Value	Auxiliary Input Value	7	PV and value of Auxiliary Input selected (e.g. valve position)
SP Value	SP	1, 3, 4, 5 & 6 if digital input is not d i5 and RSP not fitted	Target value of SP Adjustable except in Strategy 6
SP1 Value	_SP1	Digital input = d i5 . - lit if active SP = SP1	Target value of SP1 Adjustable except in Strategy 6
SP2 Value	_SP2	Digital input = d i5 . - lit if active SP = SP2	Target value of SP2 Adjustable except in Strategy 6
Local SP Value	_LSP	RSP fitted. - or - lit if the active SP = LSP	Target value of local setpoint Adjustable except in Strategy 6
Remote SP Value	_rSP	RSP fitted. - or - lit if the active SP = rSP	Target value of remote setpoint Read only
d i1 , LSP or rSP	SPS	RSP is fitted, digital input is not d i5 and SEEn is enabled in Setup mode	Selects local/remote active setpoint LSP = local SP, rSP = remote SP d i1 = selection via digital input (if configured). Note: selecting LSP or rSP will override digital input, active SP indication changes to - Adjustable except in Strategy 6
Actual SP Value	SPrP	rP is not blank	Actual (ramping) value of selected SP. Read only
Ramp Rate	rP	SPr enabled in Setup mode	SP ramping rate, in units per hour Adjustable except in Strategy 6
Active Alarm Status	ALSt	When one or more alarms are active. ALM indicator will also flash	Alarm 2 active Alarm 1 active Loop Alarm active

Manual Control

If **PaEn** is set to **EnRb** in Setup mode, manual control can be selected/de-selected by pressing the **MAN** key in Operator mode, via communications, or by changing the status of a digital input if **d i1** or **d i2** have been configured for **d iAS** in Configuration mode.

9. SERIAL COMMUNICATIONS

Refer to the full user guide (available from your supplier) for details.

ABRAF

Rua das Macieiras, 190 - B. Casa Verde
CEP: 02521-090 - São Paulo - S.P.
TEL: (0 xx11) 3858-9911
E-mail : abraf@abraf.com.br

10. SPECIFICATIONS

UNIVERSAL INPUT

Thermocouple: ±0.1% of full range, ±1LSD (±1°C for Thermocouple CJC).
Calibration: BS4937, NBS125 & IEC584.
PT100 Calibration: ±0.1% of full range, ±1LSD.
BS1904 & DIN43760 (0.00385/Ω/°C).
DC Calibration: ±0.1% of full range, ±1LSD.
Sampling Rate: 4 per second.
Impedance: >10MΩ resistive, except DC mA (5Ω) and V (47kΩ).
Sensor Break Detection: Thermocouple, RTD, 4 to 20 mA, 2 to 10V and 1 to 5V ranges only. Control outputs turn off.
Isolation: Isolated from all outputs (except SSR driver).
Universal input must not be connected to operator accessible circuits if relay outputs are connected to a hazardous voltage source. Supplementary insulation or input grounding would then be required.

REMOTE SETPOINT INPUT

Accuracy: ±0.25% of input range ±1 LSD.
Sampling Rate: 4 per second.
Sensor Break Detection: 4 to 20 mA, 2 to 10V and 1 to 5V ranges only. Control outputs turn off if RSP is the active SP.
Isolation: Slot A - Basic isolation, Slot B - Reinforced safety isolation from other inputs and outputs.

DIGITAL INPUTS

Volt-free(or TTL): Open(2 to 24VDC) = SP1, Local SP or Auto Mode, Closed(<0.8VDC) = SP2, Remote SP or Manual Mode.
Isolation: Reinforced safety isolation from inputs and other outputs.

OUTPUTS

Relay
Contact Type & Rating: Single pole double throw (SPDT); 2A resistive at 120/240VAC. 2A resistive at 120VAC when driving valve directly.
Lifetime: >500,000 operations at rated voltage/current.
Isolation: Basic Isolation from universal input and SSR outputs.
Dual Relay
Contact Type & Rating: Single pole double throw (SPDT); 2A resistive at 120/240VAC. 2A resistive at 120VAC when driving valve directly.
Lifetime: >200,000 operations at rated voltage/current.
Isolation: Reinforced safety isolation from universal input and SSR outputs.

SSR Driver

Drive Capability: SSR drive voltage >10V into 500Ω min.
Isolation: Not isolated from universal input or other SSR driver outputs.
Triac
Operating Voltage: 20 to 280Vrms (47 to 63Hz). 140Vrms valve direct drive
Current Rating: 0.01 to 1A (full cycle rms on-state @ 25°C); derates linearly above 40°C to 0.5A @ 80°C.
Isolation: Reinforced safety isolation from inputs and other outputs.

Linear DC

Resolution: 8 bits in 250ms (10 bits in 1s typical, >10 bits in >1s typical).
Isolation: Reinforced safety isolation from inputs and other outputs.

Transmitter PSU

Power Rating: 20 to 28V DC (24V nominal) into 910Ω minimum resistance.
Isolation: Reinforced safety isolation from inputs and other outputs.

SERIAL COMMUNICATIONS

Physical: RS485, at 1200, 2400, 4800, 9600 or 19200 bps.
Protocol: Modbus
Isolation: Reinforced safety isolation from all inputs and outputs.

OPERATING CONDITIONS (FOR INDOOR USE)

Ambient Temperature: 0°C to 55°C (Operating), -20°C to 80°C (Storage).
Relative Humidity: 20% to 95% non-condensing.
Supply Voltage and Power: 100 to 240VAC ±10%, 50/60Hz, 7.5VA (for mains powered versions), or 20 to 48VAC 50/60Hz 7.5VA or 22 to 65VDC 5W (for low voltage versions).

ENVIRONMENTAL

Standards: CE, UL, ULC.
EMI: Complies with EN61326 (Susceptibility & Emissions).
Safety Considerations: Complies with EN61010-1 & UL3121.
Pollution Degree 2, Installation Category II.
Front Panel Sealing: To IP66 (IP20 behind the panel).

PHYSICAL

Front Bezel Size: 1/16 Din = 48 x 48mm, 1/8 Din = 96 x 48mm, 1/4 Din = 96 x 96mm.
Depth Behind Panel: 1/16 Din = 110mm, 1/8 & 1/4 Din = 100mm.
Weight: 0.21kg maximum.